



## MX-200 Technical Specifications

# MX 200

Includes: heater, secondary air regulator, oil by-pass regulator, pump assembly, primary waste oil strainer, check valve, barometric damper, oil supply strainer and thermostat.

### FEATURES:

- UL Listed
- 200,000 BTU
- Fine grain galvanized (rust-resistant) cabinet
- MX Series High-Performance Burner
- Internal fan to reduce excess noise
- Adjustable, locking louvers
- Top, back, right or left exhaust options

Heat Range (btuh)*	to 200,000
Fuel Input (gph)	1.44
Heating Area (sq.ft.)**	to 7,000
Power Supply (AC)	120V.60HZ
Cabinet Dimensions (H x W x L)	24" x 40.5" x 46.75"
Hanging Weight (lbs.)	413
Axial fan (cfm)	2,600
Chimney Pipe***	6" Class "A"
Compressed Air****	2 CFM - 15 PSI
Combustion Chamber	12 GA CRS
Chimney Location	Top / Left Side
Warranty (Parts/Chamber)	1 year / 10 year

\* BTUH value varies with fuel type

\*\* The suggested heating area is based on buildings with minimal heat loss due to open doors, construction, materials, windows, insulation, etc...

\*\*\* Chimney package is optional \*\*\*\* Customer supplied

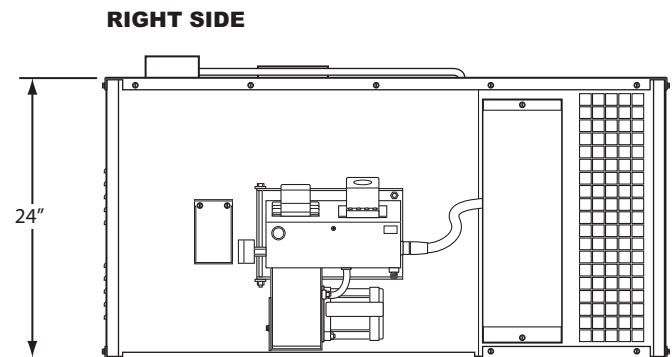
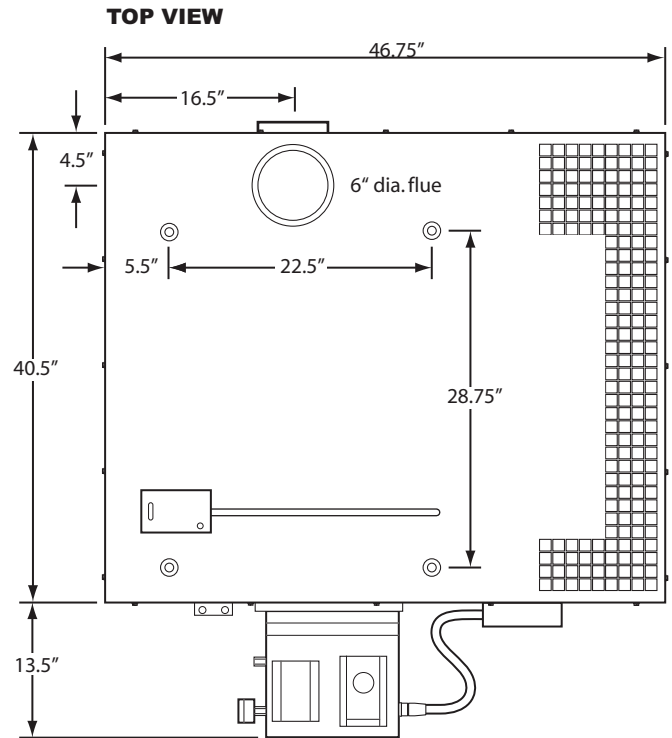

**LEFT SIDE**

